

Crane lifting eye optional
Article number: 911010605

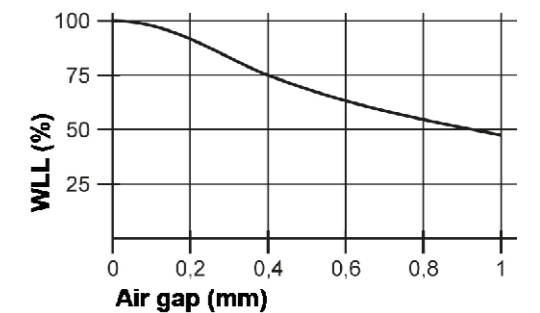
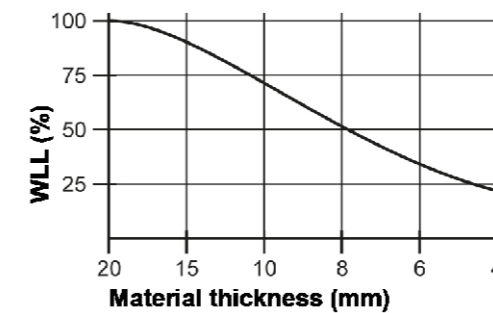
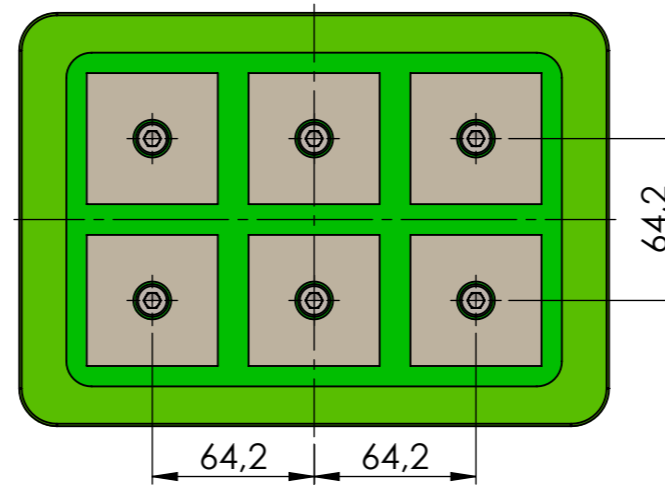
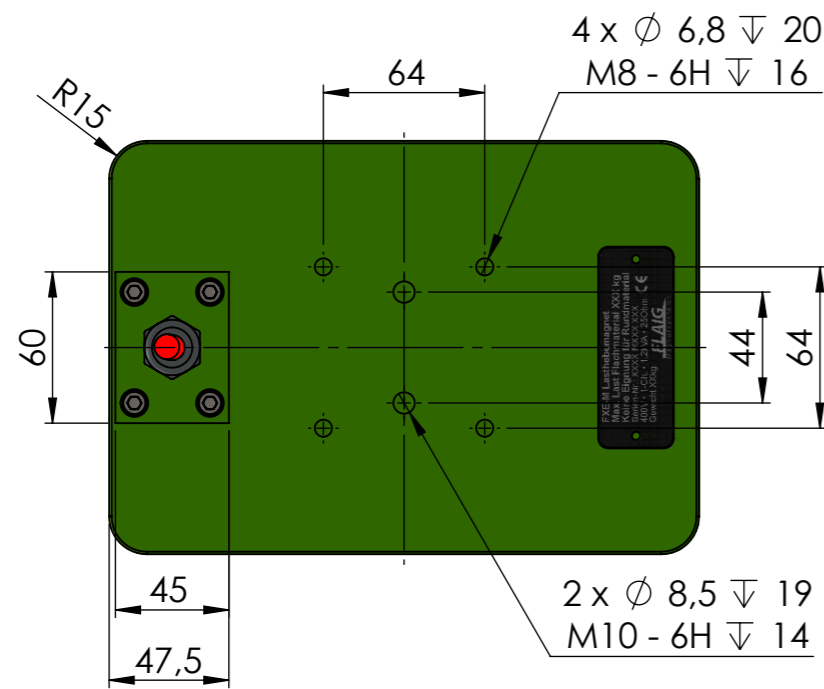
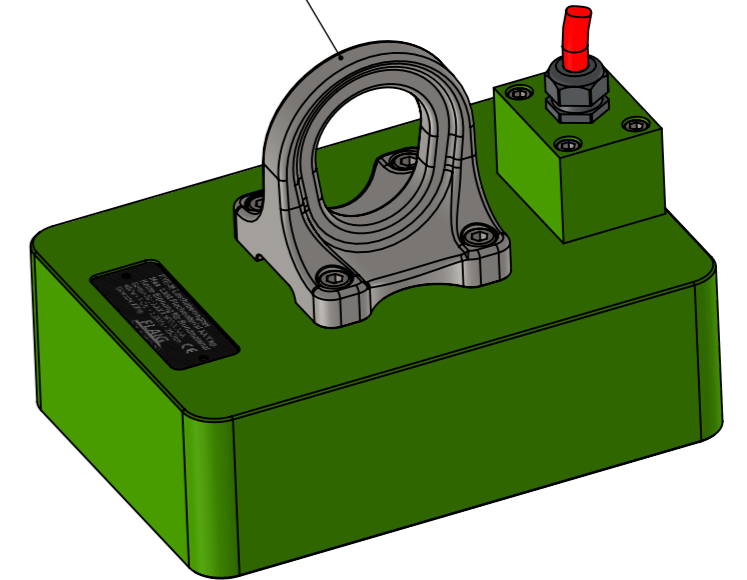

Specification FXE-M 500-50+		Schutzvermerk nach DIN ISO 16016 beachten! Nachdruck nur mit unserer Genehmigung! All rights reserved according to DIN ISO 16016! Reprint with our permission only!				tolerance	material:	weight: 21.10
Nominative Force: 22,8kN	lifting capacity EN 13155/WLL			drawn	16.09.2021	MF	drawing no.:	0015120
Materialthickness >15mm (100%)	500kg			edit	03.05.2022		description:	FXE M 500-50+
3,5kVA				appr.	12.04.2022	TW	part no.:	10610511
U: 380-480V Pulse	Protection Type IP 65						sheet	1 / 1
R: 7,8Ω	Protection category SK I			www.flaig-te.de			A3	
rev.	change	date	name	scale:	1:3	Status: Freigegeben		